



Cleaning the System



Caution • PROTECT YOUR FACTORY WARRANTY!

The recommended maintenance procedures must be performed to maintain your factory warranty. Other than the recommended cleaning procedures described in this manual, allow only Zebra authorized technicians to service the ZXP Series 3 Card Printer.

NEVER loosen, tighten, adjust, or bend, etc., a part or cable inside the printer.

NEVER use a high-pressure air compressor to remove particles in the printer.

Your Printer includes a simple cleaning system using Pre-Saturated Cleaning Cards provided. The regular use of these cards will clean and maintain important parts of your printer that cannot be reached: including Printhead, the Transport Rollers, and the Magnetic Encoder Station (optional feature).

When to Clean

Clean the Printer when:

- Print quality has been degraded.
- The LCD panel displays the message **CLEAN PRINTER**.

Phone: (800) 860-9111
Fax: (440) 306-9001
e-mail: sales@IDentiphoto.com

IDentiphoto[®]
Specialists in IDentification

1810 Joseph Lloyd Pkwy.
Willoughby, OH 44094
web: www.IDentiphoto.com

How to Clean

- Step 1.** Place the printer power switch in the ON (|) position, and then press and hold the Multi-Function Control Button for 5 seconds.
- Step 2.** When the cleaning cycle is initiated, the LCD message **REMOVE RIBBON THEN CLOSE LID** will display.

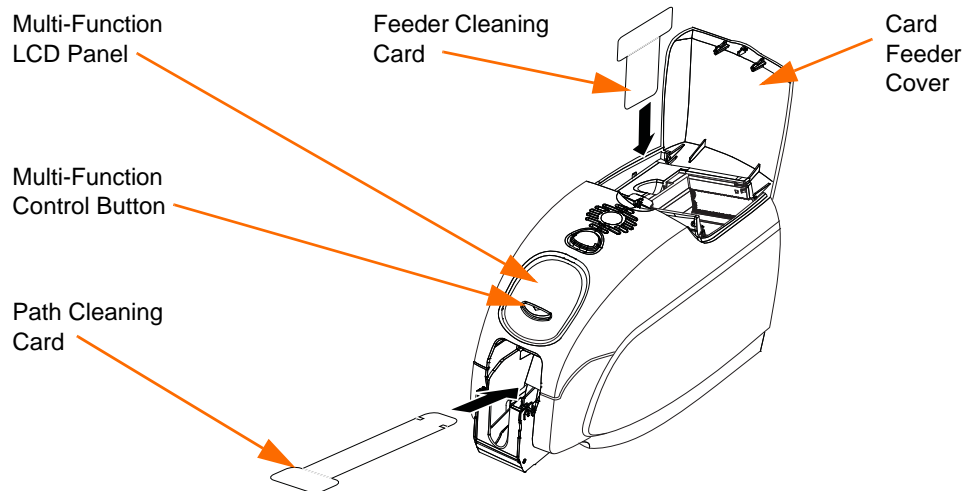

- Step 3.** After the ribbon is removed and the lid is closed, the message **EMPTY FEEDER THEN CLOSE COVER** will display.
- Step 4.** If the lid is opened and closed without removing the ribbon, the **REMOVE RIBBON THEN CLOSE LID** message will remain.
- Step 5.** Once the ribbon is removed and the cover is closed, the firmware will eject any card inside the printer. The message **EJECTING CARD** will display.
- Step 6.** The LCD will display **FEED LONG CLEANING CARD**. When the presence of the cleaning card is sensed, the rollers will take the card into the printer.
- Step 7.** When the cleaning process is done, the printer will eject the cleaning card. If the card sensor still senses the cleaning card, the message **REMOVE LONG CLEANING CARD** will display.
- Step 8.** Once the long cleaning card is no longer sensed by the card exit sensor, the message **INSERT FEEDER CLEANING CARD** will display. Open the feeder cover, and insert the feeder cleaning card.
- Step 9.** When the feeder cleaning card has been sensed by the feeder card sensor, the message **CLOSE FEEDER COVER** will display.
- Step 10.** When feeder cleaning is complete, the message **REMOVE FEEDER CLEANING CARD** will display.
- Step 11.** After the card is removed, the LCD will display **READY**. You may now reload the ribbon and cards and continue printing.

Cleaning the Printhead

Use of the cleaning cards will normally do an adequate job of cleaning the printer. However, a separate Printhead cleaning, using swabs, can remove more stubborn deposits when print anomalies persist. To avoid deposits, only use foam-tipped swabs.



Caution • Never use a sharp object to scrape deposits from the printhead. Permanent damage to the printhead will result

- Step 1.** Place the printer power switch in the OFF (O) position.
- Step 2.** Open the printer lid by pressing the cover release button, and open the cover fully to reveal the Printhead mounted on the inside of the cover.

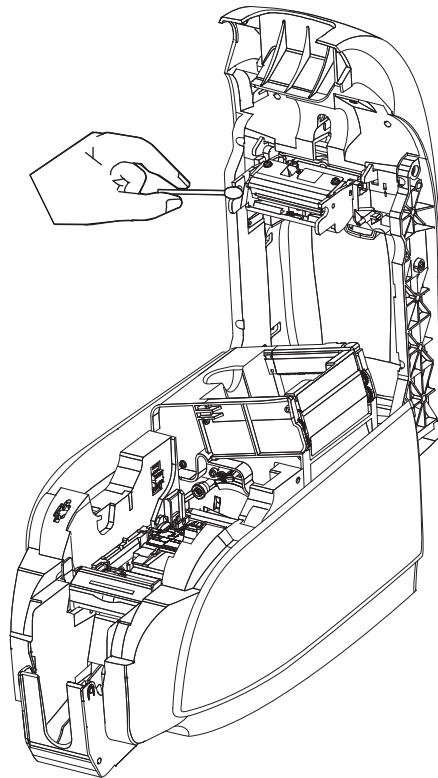

- Step 3.** Clean the Printhead by moving an alcohol-moistened swab tip side-to-side across the Printhead elements. Only use moderate force.
- Step 4.** Allow two to three minutes for the printhead to dry before placing the printer power switch in the ON (I) position.
- Step 5.** To reorder swabs, refer to the Media List on the *Windows Drivers and User Documentation CD* supplied with this printer.